



## LLOYD'S REGISTER, OMAN

### Key Facts

**Company:** Lloyd's Register

**Website:** [www.lr.org](http://www.lr.org)

**Industry:** Oil & Gas - Onshore

**Country:** Oman

### Products Used:

- PV Elite®
- NozzlePRO™

### Key Benefits:

- Highlighted non-compliances for the client
- Avoided potential code violations
- Performed complex finite element analysis (FEA) thanks to integration with NozzlePRO
- Met one-week deadline and saved 10 labor hours

### LLOYD'S REGISTER ACHIEVES FAST CERTIFICATION AT MASSIVE OMAN OIL AND GAS PROJECT.

Lloyd's Register (LR) is a global engineering, technical and business services organization owned by the Lloyd's Register Foundation, a UK charity dedicated to research and education, science and engineering. Founded in 1760 as a marine classification society, LR now operates many industry sectors based in 78 countries. Built on principles of engineering integrity and impartiality, LR provides compliance, risk and technical consultancy services to ensure the safety and sustainability of assets and businesses.

### ANALYZING LOADS ON COMPLEX VESSEL EQUIPMENT INSTALLTION

Special Technical Services LLC awarded LR a job to provide certification of MDR as per ASME Sec. VIII Div. 2 vessel codes for the Rabab Harweel Integrated Project in Oman. Equipment included a 12,800 mm long, 4,206 mm inside diameter (ID) horizontal prefilter separator with a 6,036 mm long, 1,412 ID vertical vapor column mounted on one of its 38 nozzles with a sump underneath.

The vessel operated at 30.1 bar pressure and 120 degrees Celsius. Subject to wind loading, the main horizontal vessel had to sustain the weight and bending of the attached overhead equipment, platform, and sump, as well as the associated cascading effect.

Many nozzles also had piping loads that required local analyses. To add to the challenge, the client required a short one-week deadline for the entire certification to adhere to the strict code standards.

### MEETING RIGOROUS VESSEL CODES WITH PV ELITE ANALYSIS

With PV Elite, LR could review the equipment's combined load as an integrated whole, including the underneath sump and overhead wash column and platform. This would not be possible without PV Elite. The client had changed some of nozzle loads, locations, and orientations.



With the PV Elite model in place, the team could perform the changes all at once. Some of the nozzles also required complex FEA, which was made easy by PV Elite's integration with NozzlePRO.

## COMPLETING CERTIFICATION IN JUST ONE WEEK

With PV Elite, the team could highlight the non-compliances for the client and prevent potential code violations. LR also had to create its own auditable document. This took only a small amount of time because PV Elite could simulate all three components in one model.

LR finished the initial review in one and a half days and the complete certification in one week, as the client required.

"Without PV Elite, it would have been very difficult to complete this project because of its integrated ability to analyze each component as well as the whole model," explained Sujay Pathre, P.E.

With 30 hours allotted, the team completed the entire project in just 20 hours.

"The client was very satisfied with the quick turnaround, and we ended up landing another 200-hour project assignment," Pathre added.

## AWARD-WINNING PROJECT

LR received the 2017 PV Elite Drivers of Success Runner-up Award for its use of the software. The annual Drivers of Success competition recognizes innovative applications of Hexagon PPM products, impressive project results, and significant benefits from collaboration among disciplines and the integration of the products.

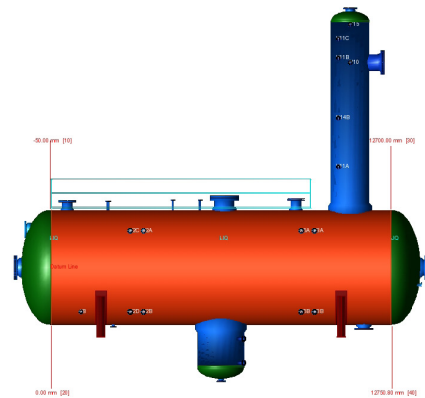
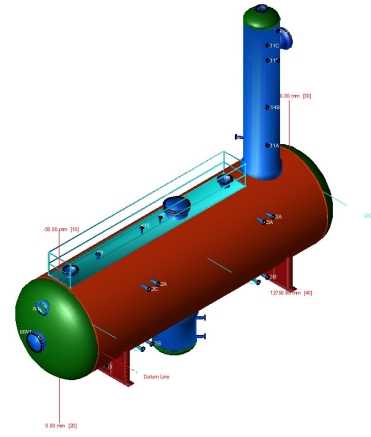

## ABOUT HEXAGON

Hexagon is a global leader in digital solutions that create Autonomous Connected Ecosystems (ACE). Our industry-specific solutions create smart digital realities that improve productivity and quality across manufacturing, infrastructure, safety and mobility applications.

Hexagon's PPM division empowers its clients to transform unstructured information into a smart digital asset to visualize, build and manage structures and facilities of all complexities, ensuring safe and efficient operation throughout the entire lifecycle.

Hexagon (Nasdaq Stockholm: HEXA B) has approximately 20,000 employees in 50 countries and net sales of approximately 3.8bn EUR. Learn more at [hexagon.com](http://hexagon.com) and follow us @HexagonAB.